

White paper:

Saving process costs with software support

Part 1: Practical tips for phases 1 – 3

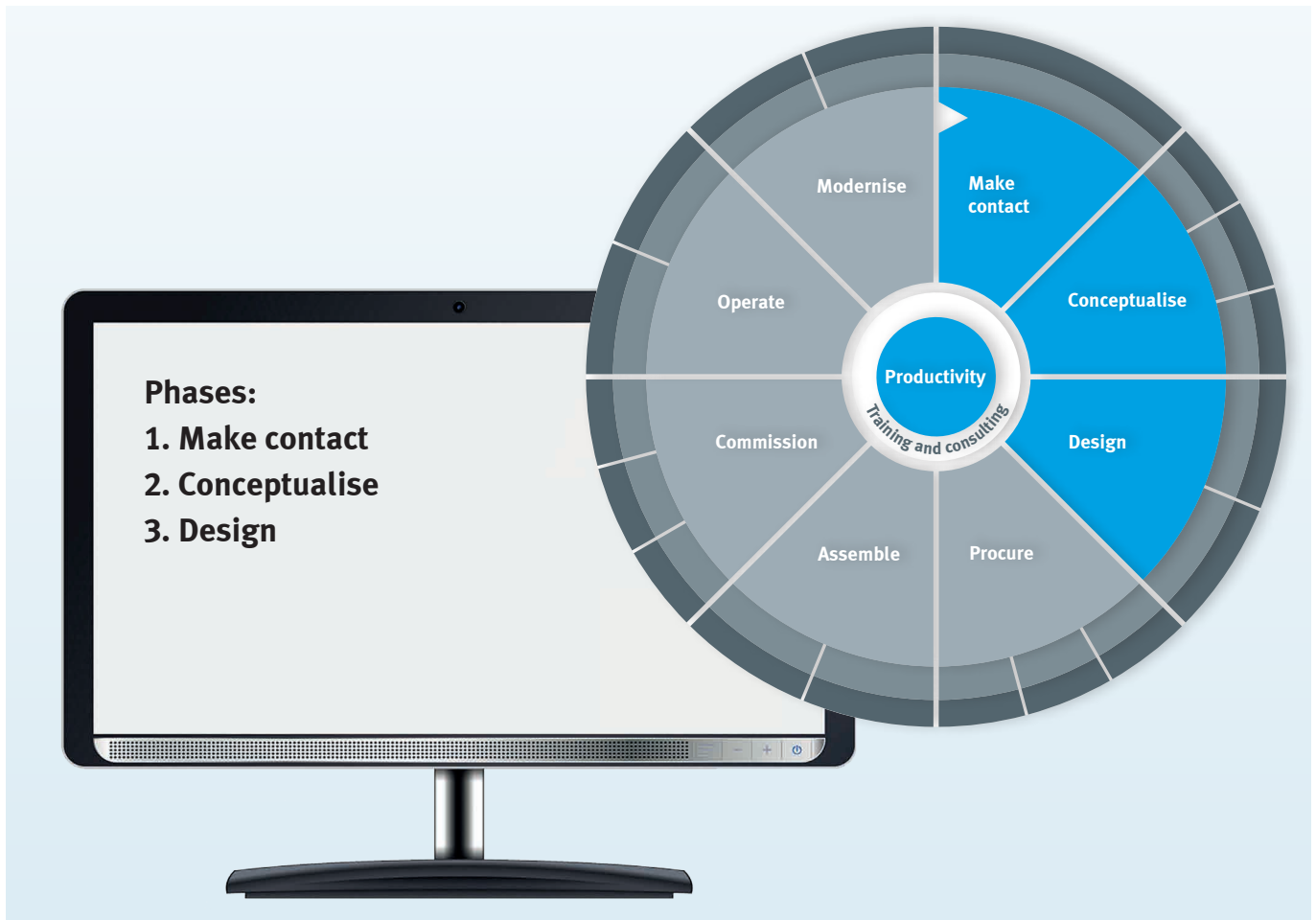

Product life cycles are becoming ever shorter¹⁾. Less and less time is available, whether for development of an installation or its possible modernisation. Companies and their employees therefore try to continuously optimise their processes as that is the only way they can remain competitive and deal with increasingly demanding challenges.

The software tools provided by system and component suppliers can support them in this; they have been available for quite some time and their number is constantly growing. The short tips in this white paper are intended as a guide to selecting tools which will help you to save valuable time in the eight-phase model of the value creation process shown above.

This white paper provides information on:

- The challenges in the individual value creation phases
- Support tools
- How you can become even more productive with networked tools, and
- Tips about which functions can be used and when.

Would you also like to save process costs in other phases?

Part 2: Practical tips for the phase "Procure"

Part 3: Practical tips for the phases "Assemble", "Commission", "Operate" and "Modernise"

¹ Sources:

<https://www.hs-pforzheim.de/De-de/Hochschule/Einrichtungen/IAF/Forschungsschwerpunkte/ppw/Seiten/Inhaltseite.aspx> (2015-10-15)
<http://www.tagesspiegel.de/wirtschaft/produktlebenszyklen-immer-schneller-neuer/4041756.html> (2015-10-15)

The phases of the value creation process and their challenges

Phase 1. Make contact – finding a supplier

As a customer, you will already be familiar with the websites of manufacturers/suppliers and/or you use search criteria and search engines to find them. The challenge is: are the product and service as described by your search criteria easy for search engines to find? And does your search result in a wide spectrum of suppliers, ensuring a good basis for comparisons?

Tip: expand your search

For good and comparable results, expand your search by using different search terms and descriptions. For example, one manufacturer may talk about valve terminals, another of valve systems. Proportional pressure regulators are sometimes referred to as E/P pressure valves.

2: Conceptualise – how to find the right product

Customers usually have a very precise idea of the solution and product/system which they require. An initial quick glance at the product portfolio will often suggest which products will meet the requirements. But it takes a great deal of specialist knowledge to make a swift decision. If the available knowledge is not sufficient to make a quick decision, a detailed fact-finding journey through individual product series/systems will have to be undertaken. The product/system comparisons required are very time-consuming and demand a high level of concentration. If the initial choice also needs to be based on price/performance comparisons and delivery times, further research will need to be done. It is also crucial to determine if the favoured product will still be available in years to come in order to ensure that the investment is future-proof.

Tips for fast and reliable product selection

Product finders are information systems which offer support when taking decisions on alternative products. They operate like a filter. The extensive product portfolio is examined step-by-step against the required product features and thus narrowed down. The chosen features are then transferred directly to the product configurator. This allows the product to be configured quickly. If a manufacturer has clearly identified the core product range, this will help with the research process. These products will generally offer an optimum price/performance ratio and be available for short delivery times.

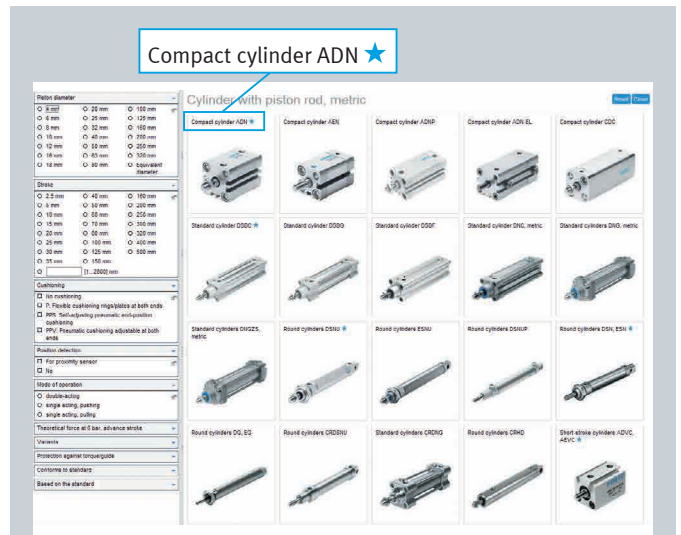

Fig. 1: Festo product finder. The core product range is indicated by a star in the product picture.

If no product finder is available, a clearly structured catalogue with basic data which can be looked up straightaway is a very good alternative. This will save you having to open a large number of individual product documents.

Comparing products and identifying phase-out products in online shops and other tools: a direct product comparison will immediately reveal the differences between products with comparable features – without a laborious manual comparison using individual product documentation. Phase-out products should preferably be indicated clearly and at an early stage in the product basket, together with information on alternative products.

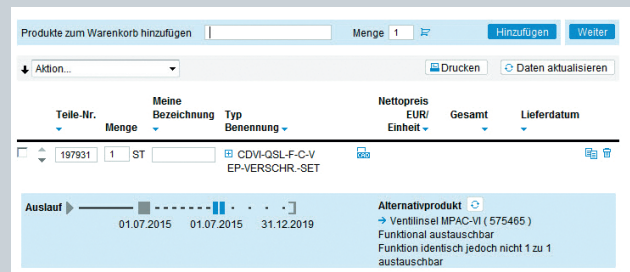

Fig. 2: Phase-out note with information on an alternative product in the Festo product basket

Engineering tools can provide support even in the design phase. They generally require some knowledge of how the product or solution will be used as well as its operating parameters.

Phase 3: Design – the fast way to a complete system

This phase involves the detailed pneumatic, mechanical and electrical design of a machine. Sometimes programming work is also started in this phase.

If the components have not yet been dimensioned, they must be sized as appropriate to the application and then configured. If important parameters change during this phase, it may be necessary to carry out the complex calculations several times. This may also change the accessories and thus result in an increased workload with regard to product configuration, CAD design and the generation of circuit diagrams and parts lists. Precise configuration data is particularly important in this context.

Tips for simple design

Engineering and simulation tools

These tools are intuitive to operate and offer significant time savings. Their support is particularly valuable in case parameters need to be changed during the configuration of complex systems. Since they eliminate the need for formulae to be calculated manually, there is less risk of calculation errors. The tools also enable safety margins to be estimated quickly.

Engineering tools, such as the Handling Guide Online, PositioningDrives or SoftStop from Festo, are the best solution as they can be used to configure complete systems.

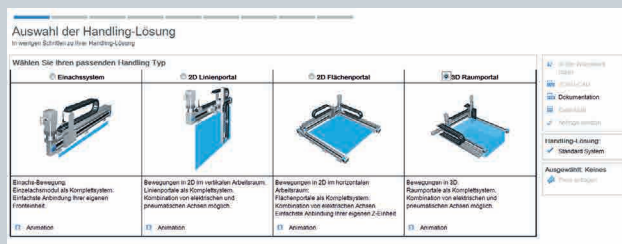

Fig. 3: Example of an engineering tool – the Festo → **Handling Guide Online**

CAD-based accessory selection with tools such as the Festo Design Tool 3D or directly on the product in the catalogue can speed up the design process, as can a CAD plug-in. This eliminates the need to convert system-neutral formats.

The link to the product catalogue and Online Shop then enable all the other data to be accessed quickly, such as CAD models, price and delivery time information, macros for electrical or fluid-power circuit diagrams and suitable accessories. If the appropriate circuit diagram macros are not available as downloads for configurable products and the chosen configuration, it is possible that other software tools for creating circuit diagrams can offer this function, as long as they can recognise order codes.

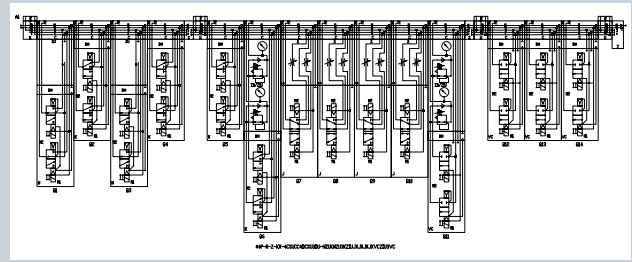

Fig. 4: Pneumatic circuit diagram automatically generated in → **FluidDRAW** on the basis of the order code

3D product configurators and CAD plug-ins

These are also tools which can be used to reduce process costs. Intelligent 3D product configurators for assemblies, such as the Festo Design Tool 3D, can contribute to significant time savings. They allow suitable accessories to be selected visually by "dragging and dropping" and placed automatically, thus ensuring correct assembly. These configurators also reduce errors when selecting accessories, since the accessories adapt automatically when the size of the main product is changed. The end result of the configuration process is a single CAD assembly which can be ordered as a single unit, which is advantageous for all subsequent processes.

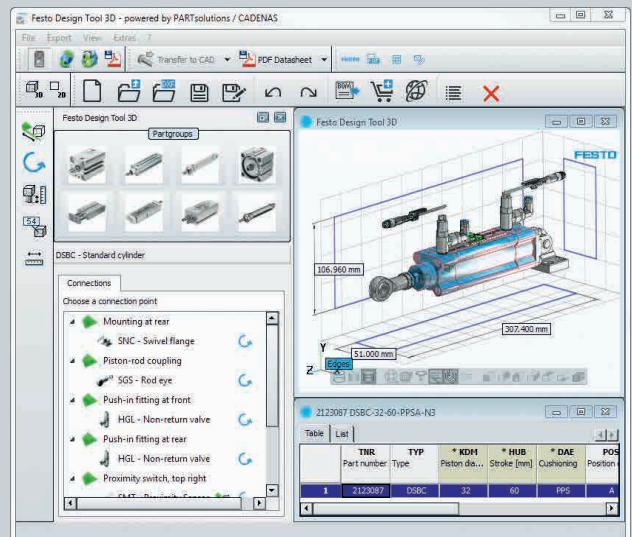

Fig. 5: Example of a 3D product configurator: → **Festo Design Tool 3D**

If a 3D product configurator for assemblies is not available, or if it does not include all the necessary product ranges, other software can also help with the visualisation and generation of 2D/3D CAD data. CAD data can be transferred directly from these programs. References to accessories can be viewed without further searches in the product documentation. These tools are often supplemented by CAD plug-ins, allowing users to work entirely within the CAD system without the need to exit the system.

If programming is also to be started in this phase, product documentation, device description files and possibly function modules will be required. With suitable function blocks third-party controllers, for example, can be implemented much faster. However, it is important to ensure that the function blocks are easily accessible and that clearly visible answers are given, even to special questions about product integration. Otherwise it is inevitable that time will be lost and additional work will be required.

Tips for fast programming

Product manufacturers' information and community platforms

These platforms combine information other than just product documentation. You can find there, among other things, ready-made software modules, EPLAN macros for circuit diagram generation or special expert knowledge (application notes). If users cannot find what they are looking for, the product manufacturers' support communities may be able to help. Here, questions from users are answered quickly by technical support staff. These communities often also offer other useful tips and information which help users to reach their goal faster.

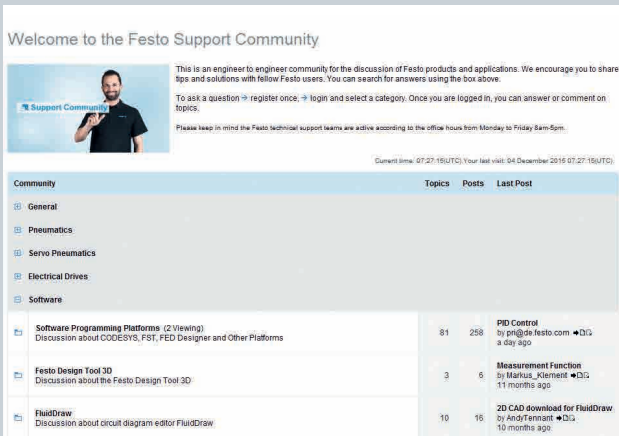

Fig. 6: Examples of a community platform: → Support community

Fast programming with standard modules and designations, thanks to optimised data profiles

Festo has developed an optimised data profile tailored to handling and positioning applications. In the case of the Festo Handling and Positioning Profile FHPP, the command structure and commands are standardised, which saves a significant amount of time during programming. With FHPP Festo motor controllers can be actuated using a fieldbus interface, via standardised control and status bytes. This means that the module always has the same appearance for the programmer, regardless of which PLC and Festo controllers and motors are used.

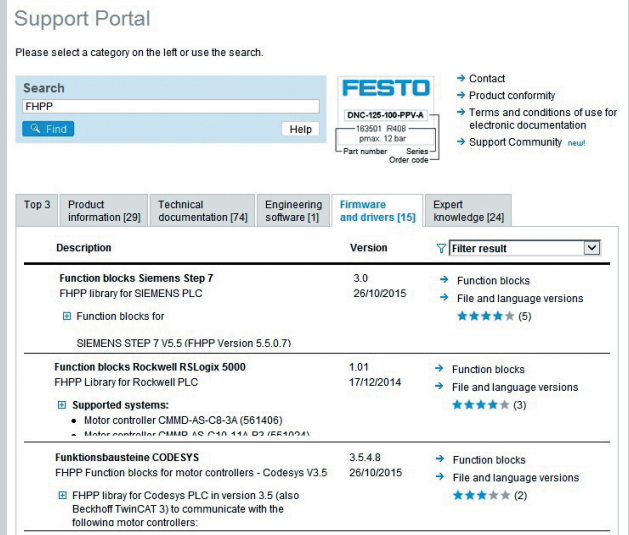

Fig. 7: Examples of FHPP libraries on the information platform: → Festo Support Portal

A simple example

A pipe diverter system requires a cylinder with a stroke of 100 mm, integrated self-adjusting cushioning, a rod clevis and swivel flange, 2 one-way flow control valves, 2 cylinder sensors and a bistable 5/2-way directional control valve 24 V DC, IP40. The cylinder and valve should be sourced from a manufacturer's core product range, which should be attractively priced and available at short notice. The switch-over of the diverter should take between 0.5 – 0.8 seconds with a maximum load of 20 kg.

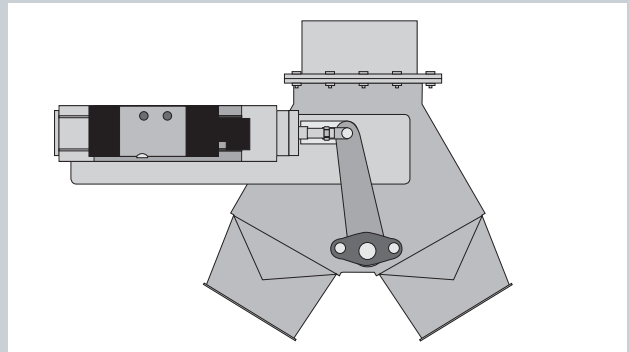

Fig. 8: Pipe diverter system

Phase	Process with little software support	Process with good software support	Time difference between processes
2. Design			
Product search and configuration in the online catalogue	Select and configure the cylinder and valve without a product finder	Define the cylinder and valve with the aid of a product finder The data from the search criteria will be transferred to the configurator Results of product finders: 6 out of 26 cylinder series and 1 out of 18 solenoid actuated individual valves provide the required features.	Factor 2.5 and higher
3. Build			
Checking the cycle time	Manually using formulae	With an engineering tool Results of pneumatic simulation: Positioning time (return) 0.7 seconds with cylinder DSBC32-100-PPSA-N3, one-way flow control valve GRLA 1/8-... and solenoid valve VUVG-L14-B52-T-...	Factor 10 and higher
Compile all accessories including CAD models	Transition from the engineering tool to the product in the catalogue where suitable accessories are offered directly for selection. The components can be downloaded individually or as a package. The individual components are assembled in the CAD system.	Compilation of the cylinder module using a 3D product configurator (Festo Design Tool 3D). The module (cylinder with accessories) can then be transferred directly to the CAD system, where all CAD relationships are available in native form.	Factor 3.8 and higher
Generation of a pneumatic circuit diagram	Search for standard symbols and create a circuit diagram with a manually generated parts list	The circuit diagram generation software (FluidDraw) automatically recognises the product designation or, alternatively, the complete product basket can be read in. All symbols are immediately displayed on the worksheet and the parts list is generated dynamically.	Factor 2.8 and higher
4. Procure			
All the necessary data must be available in e-procurement systems and be up to date before procurement can be started.	Manual update of supplier data, price, delivery time, etc.	Data harmonisation if individual components are ordered ordering via the OCI interface	Factor 2.5 and higher for harmonising component data
	Ordering individual components by fax, email, telephone, online	Ordering a complete cylinder module as one order item (directional control valve separately) To ensure simple traceability, the details of the supplier parts list should be accessible at any time	Factor 2.5 and higher if it is possible to order as one order item

Publisher/author:

Festo AG & Co. KG
Philipp Wahl
Marketing Concepts
E-mail: philipp.wahl@festo.com

Your local contact:

You will find details of your local contact on the website of your Festo national company.